

Product Description

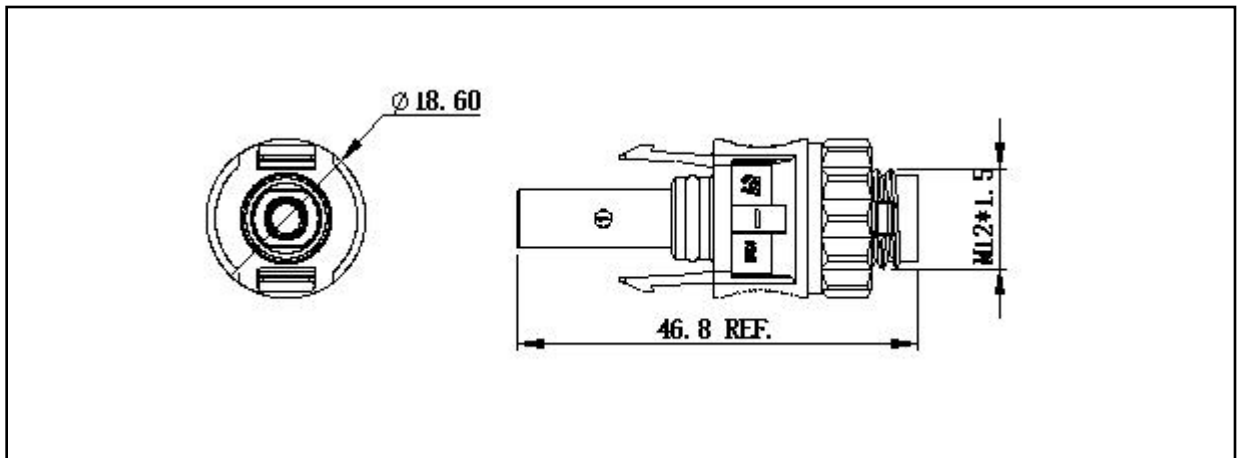
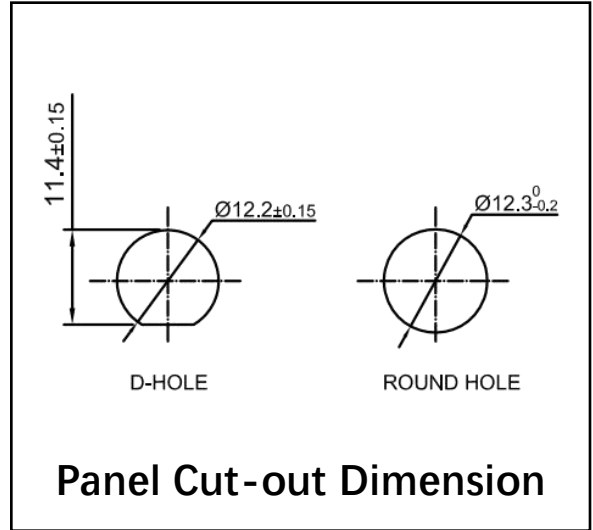
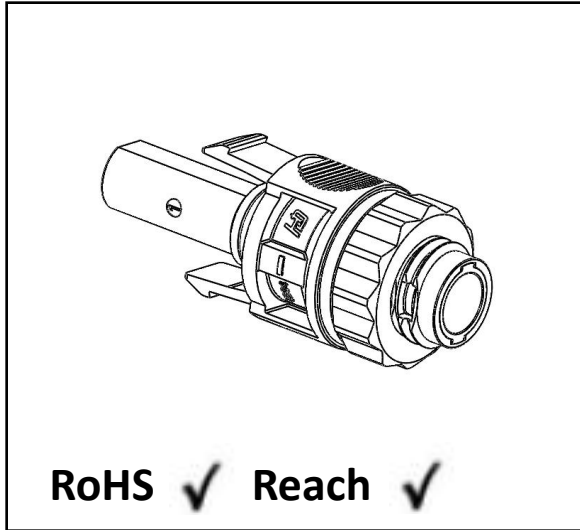

Product Info.		
Product No.	Cut-out Type	Applicable Wire Size
10155010002	ROUND	4~6mm ²
10155010003	ROUND	8AWG
10155010004	D	4~6mm ²

Technical Data

Electrical Specification

Rated Voltage	1500V DC
Rated Impulse Voltage	16KV
Rated Current	41A for 4mm ² 55A for 6mm ² 70A for 8AWG
Wet Insulation Resistance	≥500MΩ
Contact Resistance	≤0.4mΩ

Mechanical Specification

Mating Cycle	≥500
PIN Retention Force	≥80N
Cable Retention Force	≥180N
Wire Size	4mm ² ~8AWG (5.5mm~7.25mm)
Unlock Mode	Non-tool unlock Tool unlock
Connector Retention Force	≥ 80N
Connector Pull-Out Force	≤20 N

Environmental Specification

Waterproof Rate	IP65/IP68 (1m,1H)
Application Temperature	-40 °C~+85°C
Flamming Level	UL94-V0

Material

Plastic Material	PA(f1)
Pin Material	Copper Alloy,Sn Plating
Sealing Material	Sillicone Rubber

Certification/Certificate

TUV Certification

Logo	Certification	Reference Standard	Certification No.
	TÜV Rheinland	IEC62852	R50506030

Installation Tools



Rivet Plier



Wire Stripper



Wrench

Installation Instruction

Dimension of stripping wire inside machine

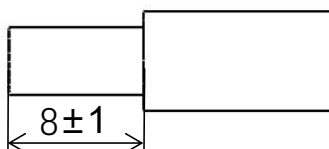

Installation Steps

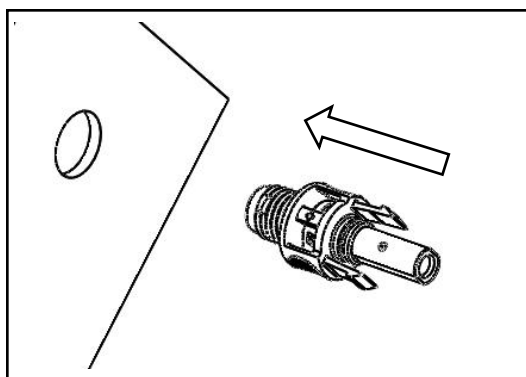

1. Assemble the panel mount negative connector on the panel hole.

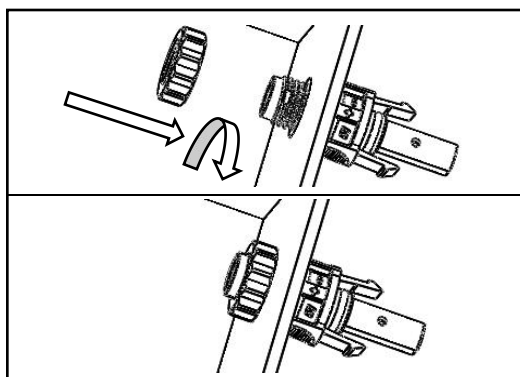

2. Clockwise tighten the nut through the wrench with torque $3.8 \pm 0.2 \text{ N.m}$.

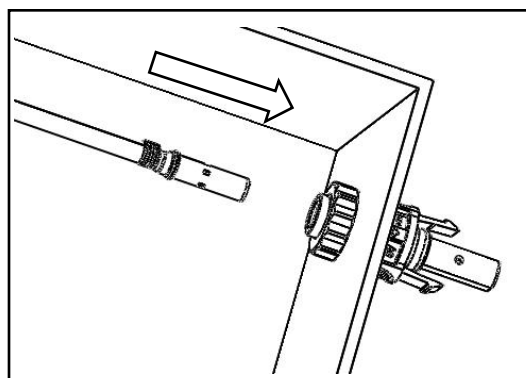

3. Crimping the stripped wire to the terminal, then insert it into the panel mount negative connector.

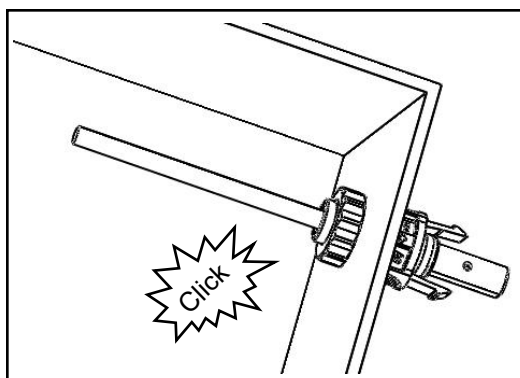

4. Complete the installation while hearing "Click" sound.

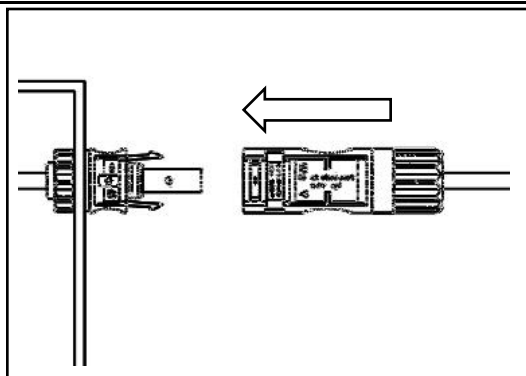

5.Insert cable end negative connector into panel mount negative connector.

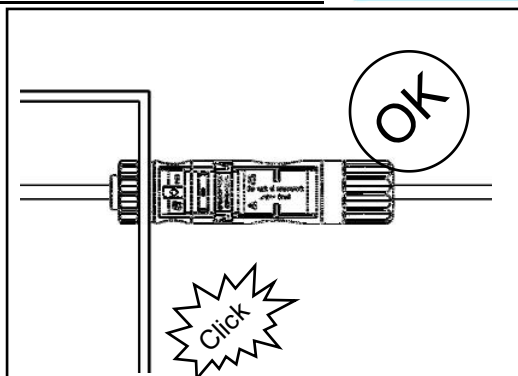

6.Complete the installation while hearing "Click" sound.

Unlock Instruction

(Please use the dedicated unlock wrench as shown)

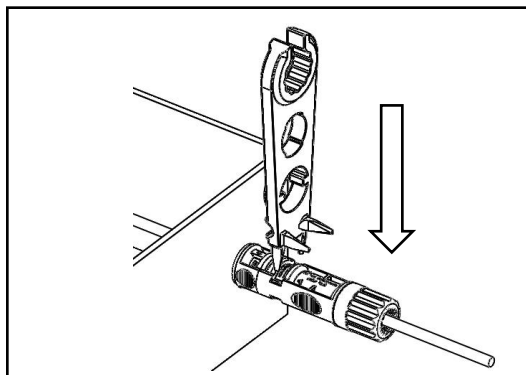

Insert the wrench pawl into the slot position of the connector rubber core.

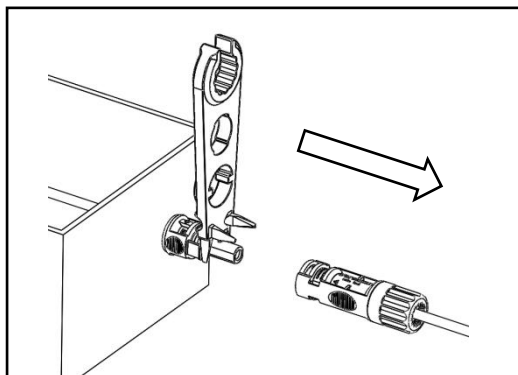

Push the slot part to separate it with the wrench, then pull out the connector.

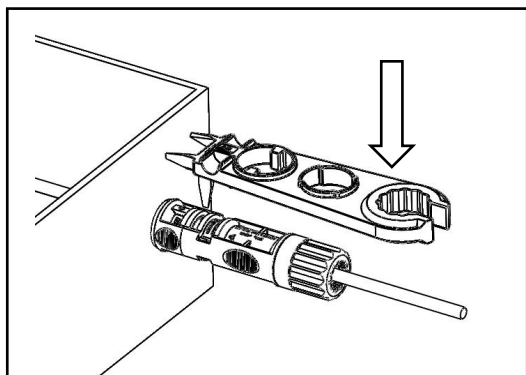

Insert the wrench pawl into the slot position of the connector rubber core.

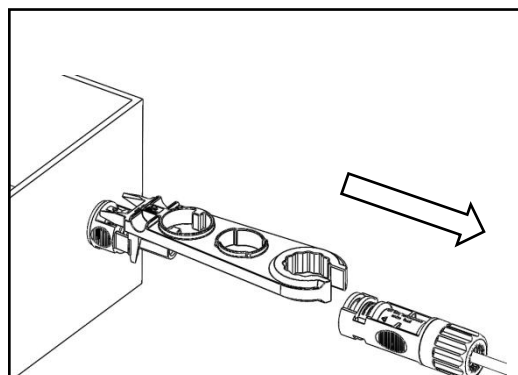

Push the slot part to separate it with the wrench, then pull out the connector.

Unlock Instruction(Non-tool Unlock)

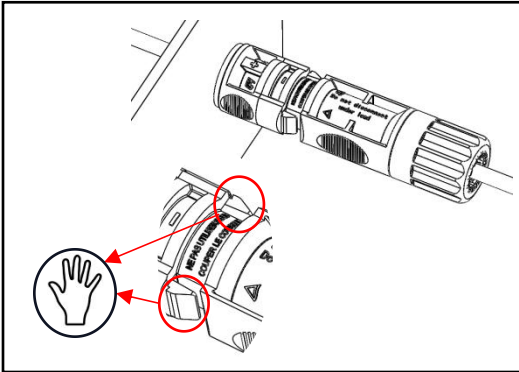

Hold and press the wings of the panel mount negative connector.

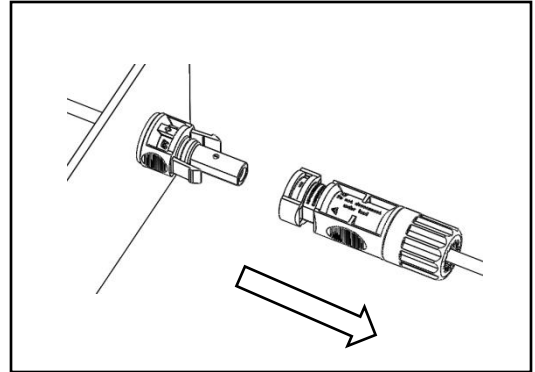

Then pull out the connector.