

Product Description (Non-tool unlock)

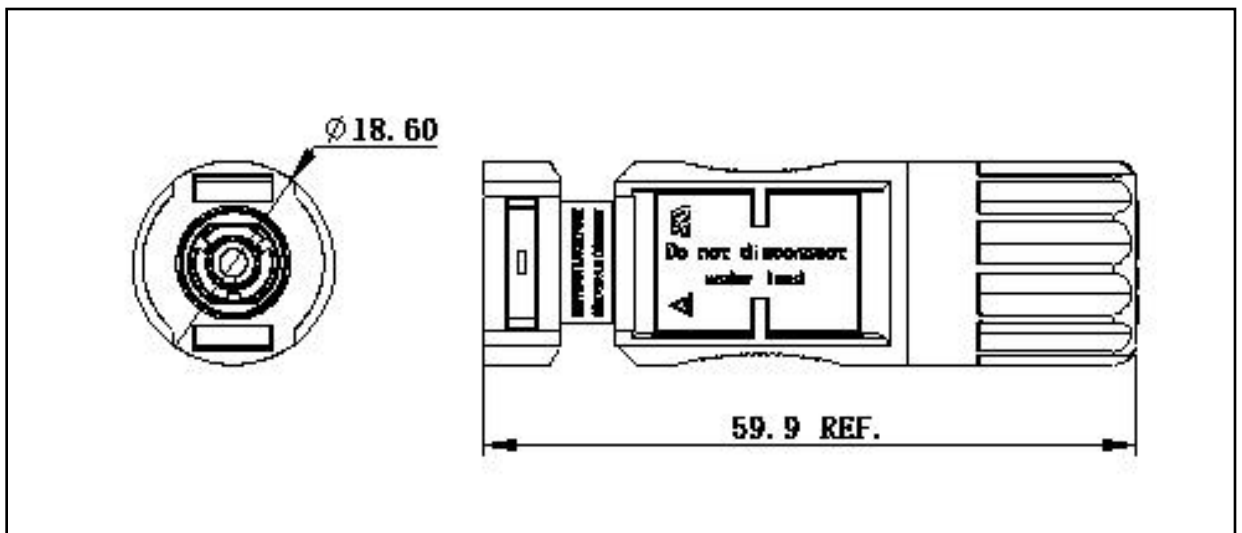
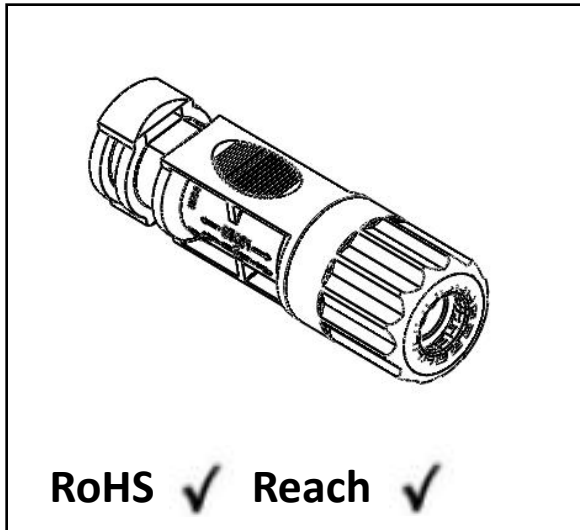

Product Info.

Product No.	Wire Size
10455010002	4~6mm ² PV
10455010005	4~6mm ² PV-AL
10455010006	8AWG

Product Description (Tool unlock)

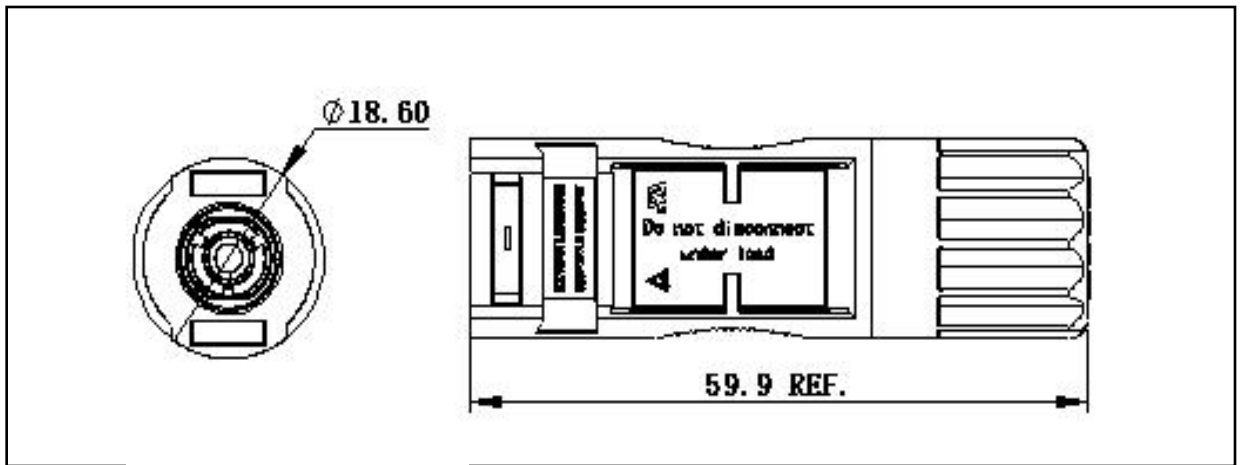
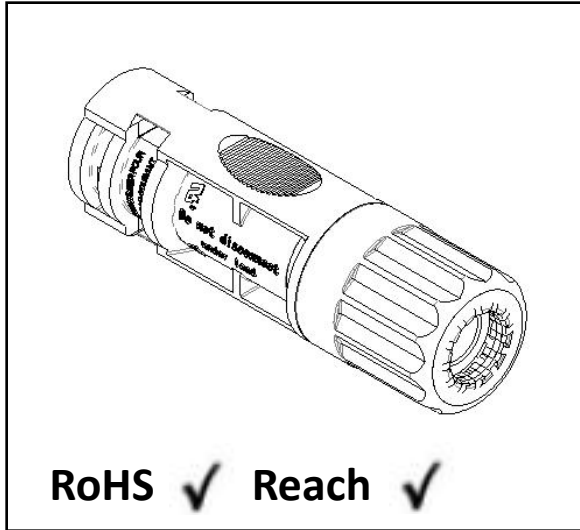

Product Info.

Product No.	Wire Size
10455010003	PV (4~6mm ²)
10455010004	PV-AL (4~6mm ²)
10455010007	8AWG

Technical Data

Electrical Specification

Rated Voltage	1500V DC
Rated Impulse Voltage	16KV
Rated Current	41A for 4mm ² 55A for 6mm ² 70A for 8AWG
Wet Insulation Resistance	≥500MΩ
Contact Resistance	≤0.4mΩ

Mechanical Specification

Mating Cycle	≥500
PIN Retention Force	≥80N
Cable Retention Force	≥180N
Wire Size	4mm ² ~8AWG (5.5mm~7.25mm)
Unlock Mode	Non-tool unlock Tool unlock
Connector Retention Force	≥ 80N
Connector Pull-Out Force	≤20 N

Environmental Specification

Waterproof Rate	IP65/IP68 (1m,1H)
Application Temperature	-40 °C~+85°C
Flamming Level	UL94-V0

Material

Plastic Material	PA(f1)
Pin Material	Copper Alloy,Sn Plating
Sealing Material	Sillicone Rubber

Certification/Certificate

TUV Certification

Logo	Certification	Reference Standard	Certification No.
	TÜV Rheinland	IEC62852	R50506030

Installation Tool



Rivet Plier



Wire Stripper



Wrench

Installation Instructions

Dimension of stripping wire

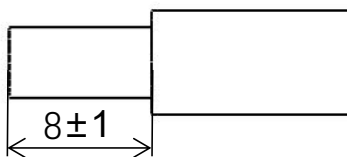

Installation Instructions

Installation Steps

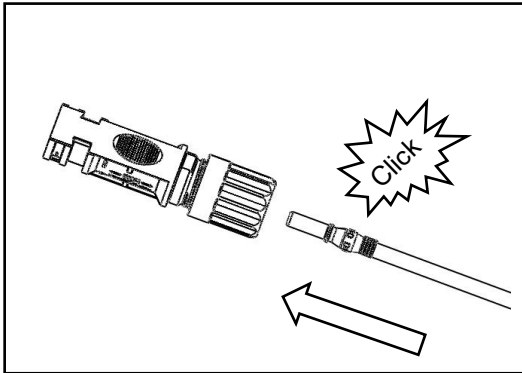

1. Crimping the stripped wire to the terminal, then insert it into the cable end negative connector while hearing the "Click" sound.

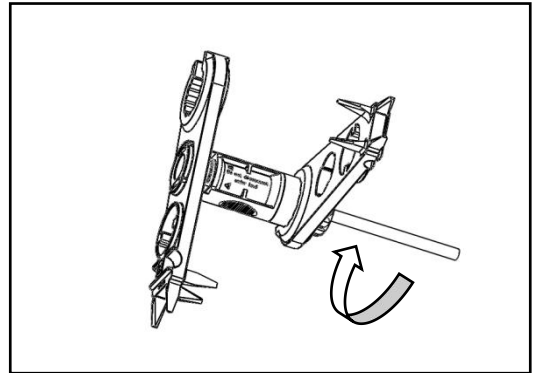

2. Clockwise tighten the nut through the wrench with torque $2 \pm 0.1 \text{ N.m}$.

Positive and Negative butt

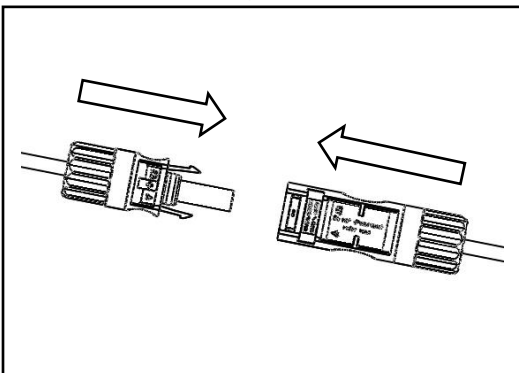

Cable end negative connector and cable end positive connector butt.

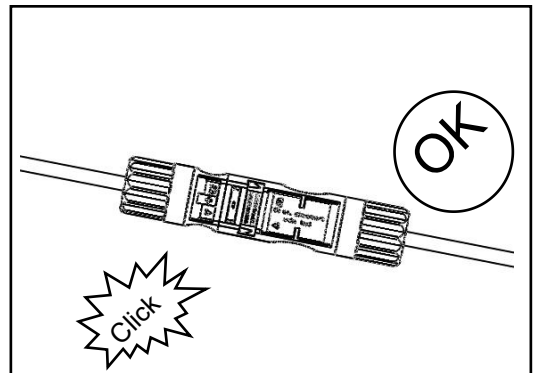

Complete the installation while hearing "Click" sound.

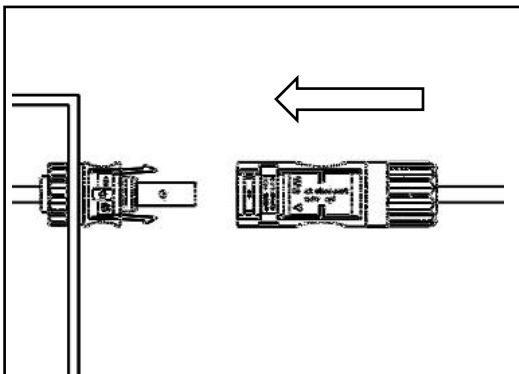

Insert cable end negative connector into panel mount negative connector.

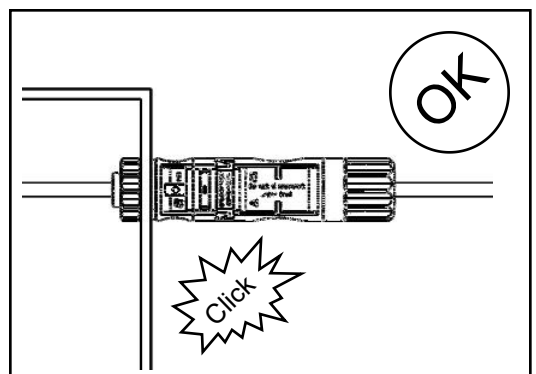

Complete the installation while hearing "Click" sound.

Tool Unlock Instruction

(Please use the dedicated unlock wrench as shown)

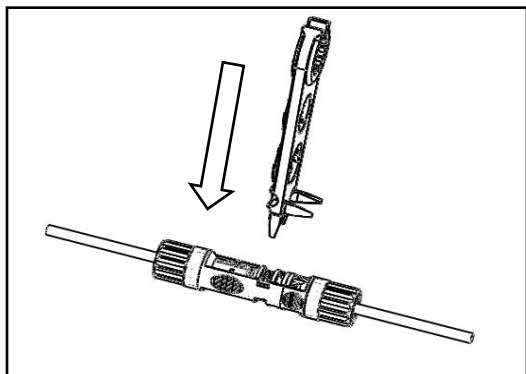

Insert the wrench pawl into the slot position of the connector rubber core.

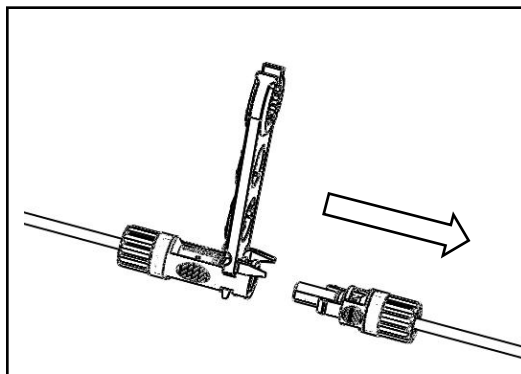

Push the slot part to separate it with the wrench, then pull out the connector.

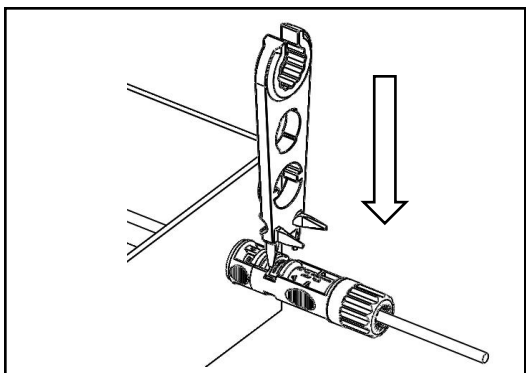

Insert the wrench pawl into the slot position of the connector rubber core.

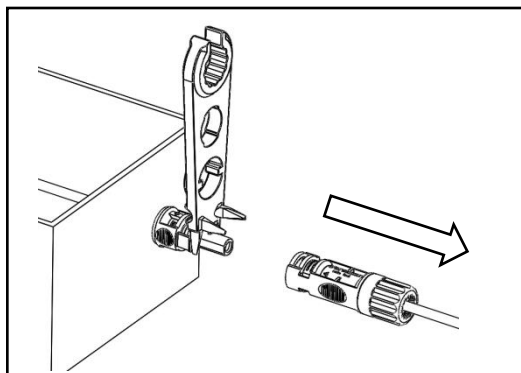

Push the slot part to separate it with the wrench, then pull out the connector.

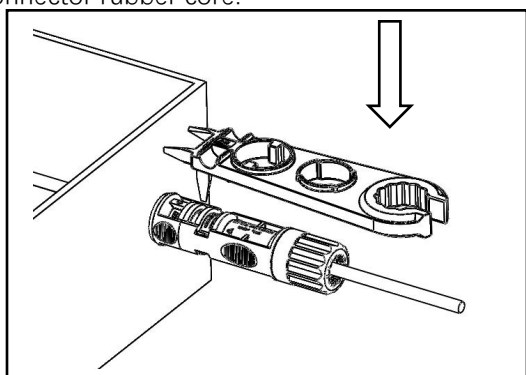

Insert the wrench pawl into the slot position of the connector rubber core.

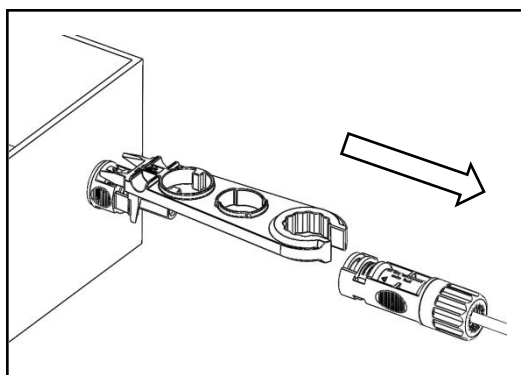

Push the slot part to separate it with the wrench, then pull out the connector.

Non-tool Unlock Instruction

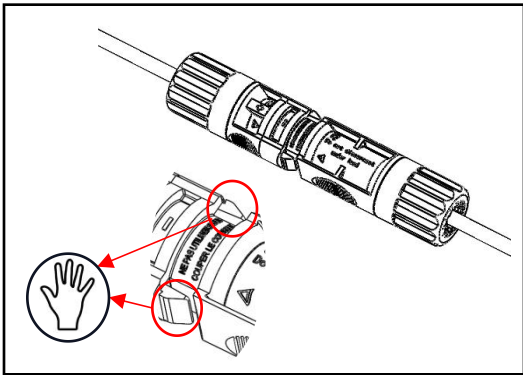

Hold and press the wings of the cable end negative connector.

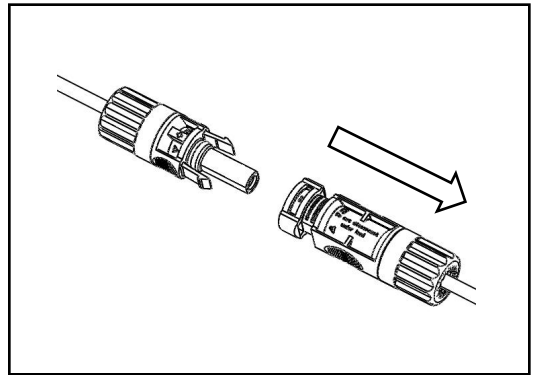

Then pull out the connector.

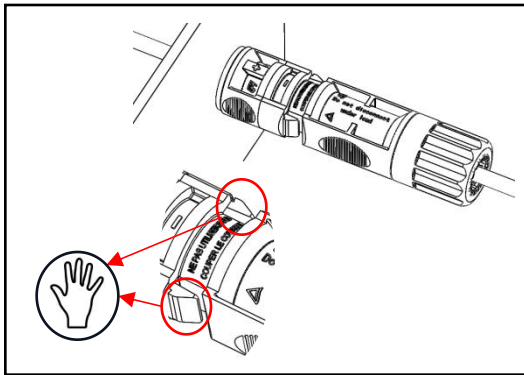

Hold and press the wings of the cable end negative connector.

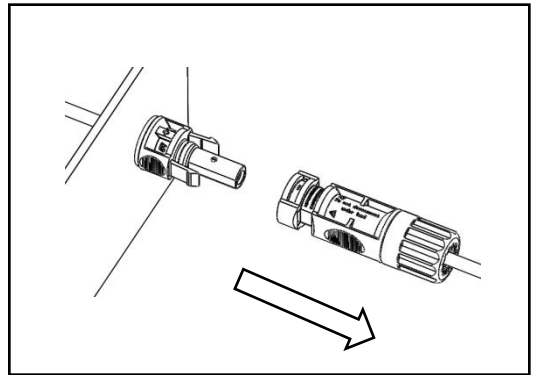

Then pull out the connector.